

INSTALLATION INSTRUCTIONS

DESCRIPTION: GYTR Billet Ignition Cover Kit
PART NUMBER: BCR-E54G0-V0
MODEL: 2005-2021+ YZ250
2016-2021+ YZ250X

GYTR[®]
GENUINE YAMAHA TECHNOLOGY RACING
PERFORMANCE PRODUCTS

 **YAMAHA**
GENUINE
Parts & Accessories

⚠ WARNING

Please read and understand these instructions completely before installation to avoid possible injury, or damage to the accessory or vehicle.

IMPORTANT: YZ models are for closed-course competition only regardless of modification.

NOTICE:

Installation of this kit requires a torque wrench and should be performed by an authorized Yamaha dealer or a qualified mechanic.

WARRANTY INFORMATION:

In the United States, see your Yamaha dealer for a copy of the Yamaha Genuine Parts and Accessories Limited Warranty.

DEALER OR INSTALLER:

These instructions contain important information for future reference and *must* be given to the customer.

PARTS LIST:

No.	Part Number	Description	Qty
--	BCR-E54G0-V0	GYTR Ignition Cover Kit	--
①	*	Case Cover	1
②	5CU-15451-00	Case Cover Gasket	1
③	95022-06030	M6x1.0x30 Hex Head Flanged Bolt	5

* Part supplied with kit only and not available separately.

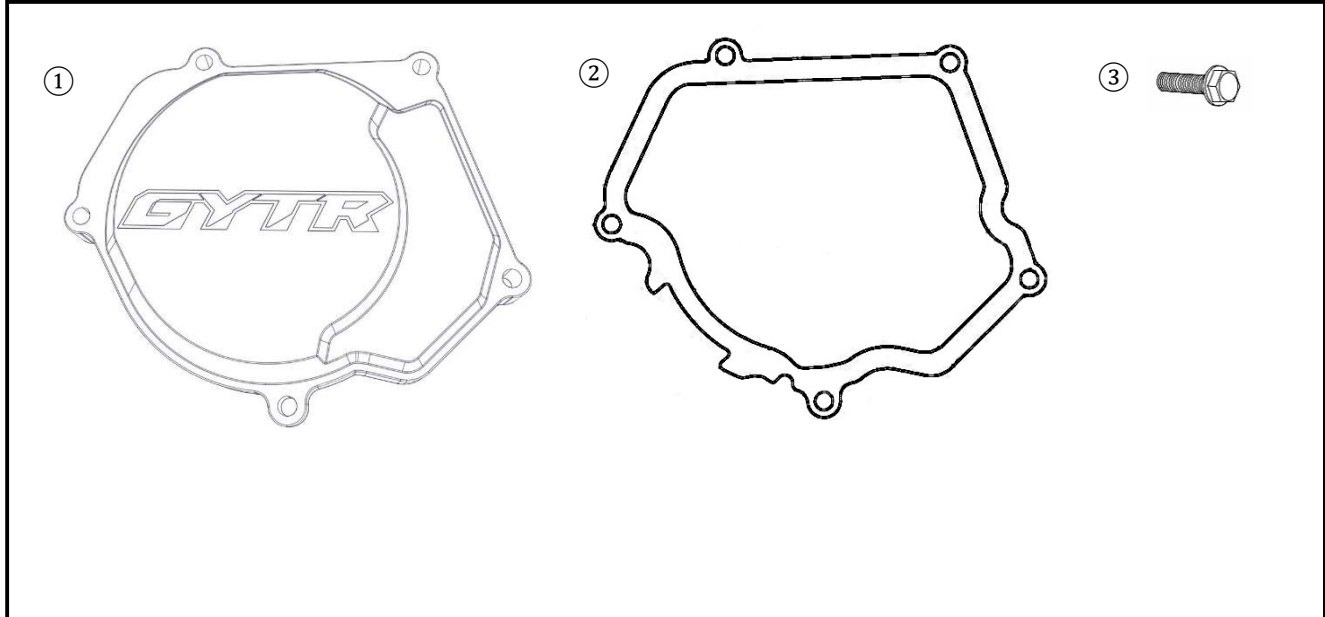

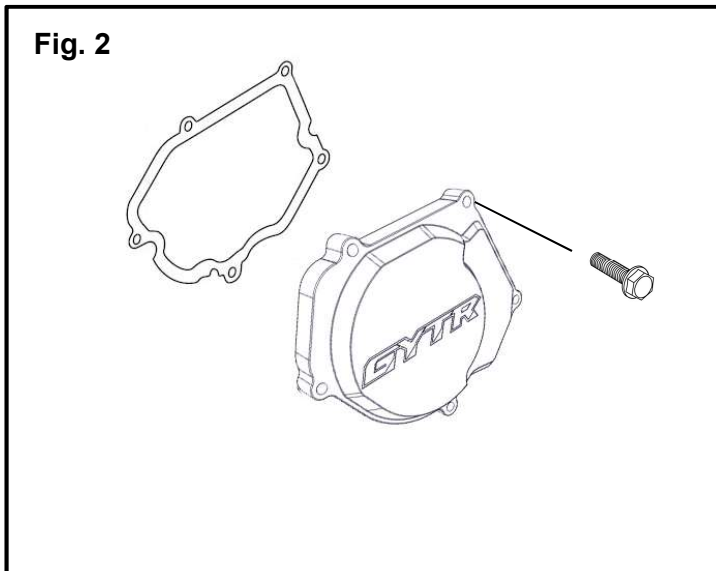
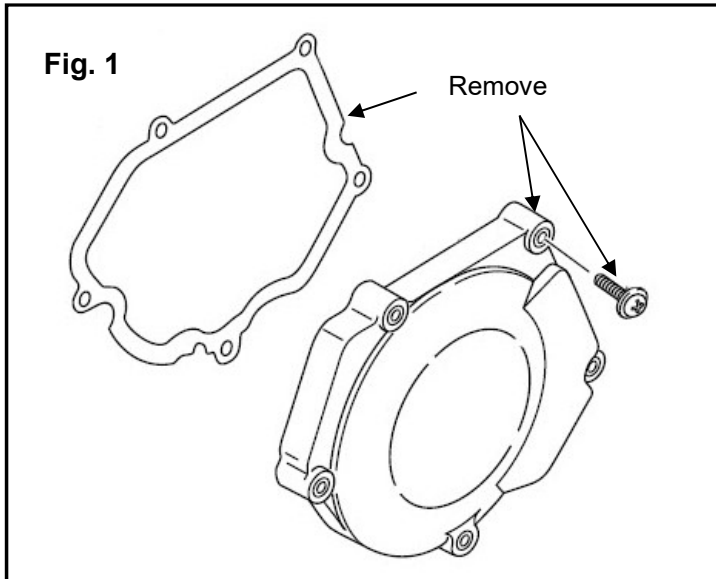

PREPARATION:

- Place the motorcycle on a secure and level surface.
- Clean the mounting surfaces before beginning installation.

INSTALLATION:

1. Remove the stock screws and the stock cover. They will not be reused. (Fig. 1)
2. Remove the stock gasket.
3. Place the ② Case Cover Gasket on the ① Case Cover. (Fig. 2)
4. Align both parts to the engine case and thread in the ③ M6x1.0x30 Hex Head Flanged Bolts. (Fig. 2)
5. Torque the bolts to 10Nm (1.0 m-kg or 7.3 ft-lb).

MAINTENANCE:

Periodically check hardware for tightness and re-torque as necessary.

CARE AND CLEANING:

Wash using a mild soap and water solution and soft cloth.

CUSTOMER SERVICE:

For further information see your Yamaha dealer.

ESTIMATED TIME TO INSTALL: 0.25 HR